

MUSTANG AERONAUTICS, INC.

1990 Heide Dr
Troy, MI 48084

(248) 649-6818
fax (248) 688-9275
www.MustangAero.com

Mustang II & Midget Mustang Service Bulletin

Date: 5/22/00

Subject: Change to outboard horizontal stabilizer and elevator hinge brackets
(p/n 250.308 & 250.321)

This change applies to both the Mustang II and Midget Mustang. The parts are interchangeable.

This change is not required for existing aircraft that do not have hinge alignment issues (binding) of the elevators. It was primarily made to simplify construction and manufacturing. It will also help to eliminate the possibility of cracks in the horizontal stabilizer spar around the doublers at the outer elevator hinge points due to misalignment of the hinge points.

The larger spar doublers, additional attach bolts for p/n 250.308, and the adjustment capability of the elevator attach points using rod end bearings make the new configuration superior in many ways.

It is possible to use the older steel elevator hinge bracket (p/n 250.321) with the new multiple bracket version of the stabilizer hinge brackets (p/n 250.308). The spacing between the 250.308 brackets just needs to be changed accordingly.

Original Configuration

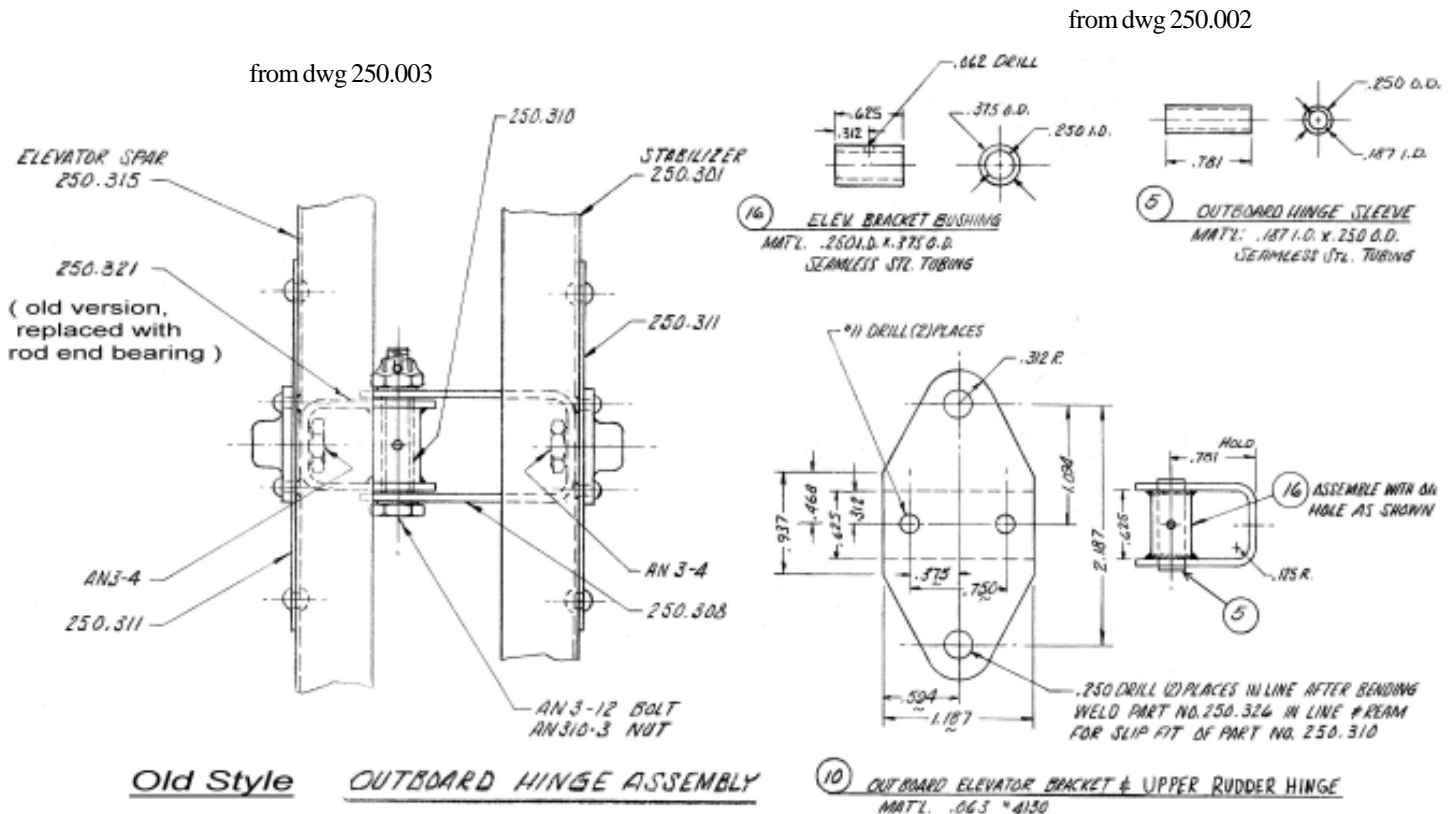

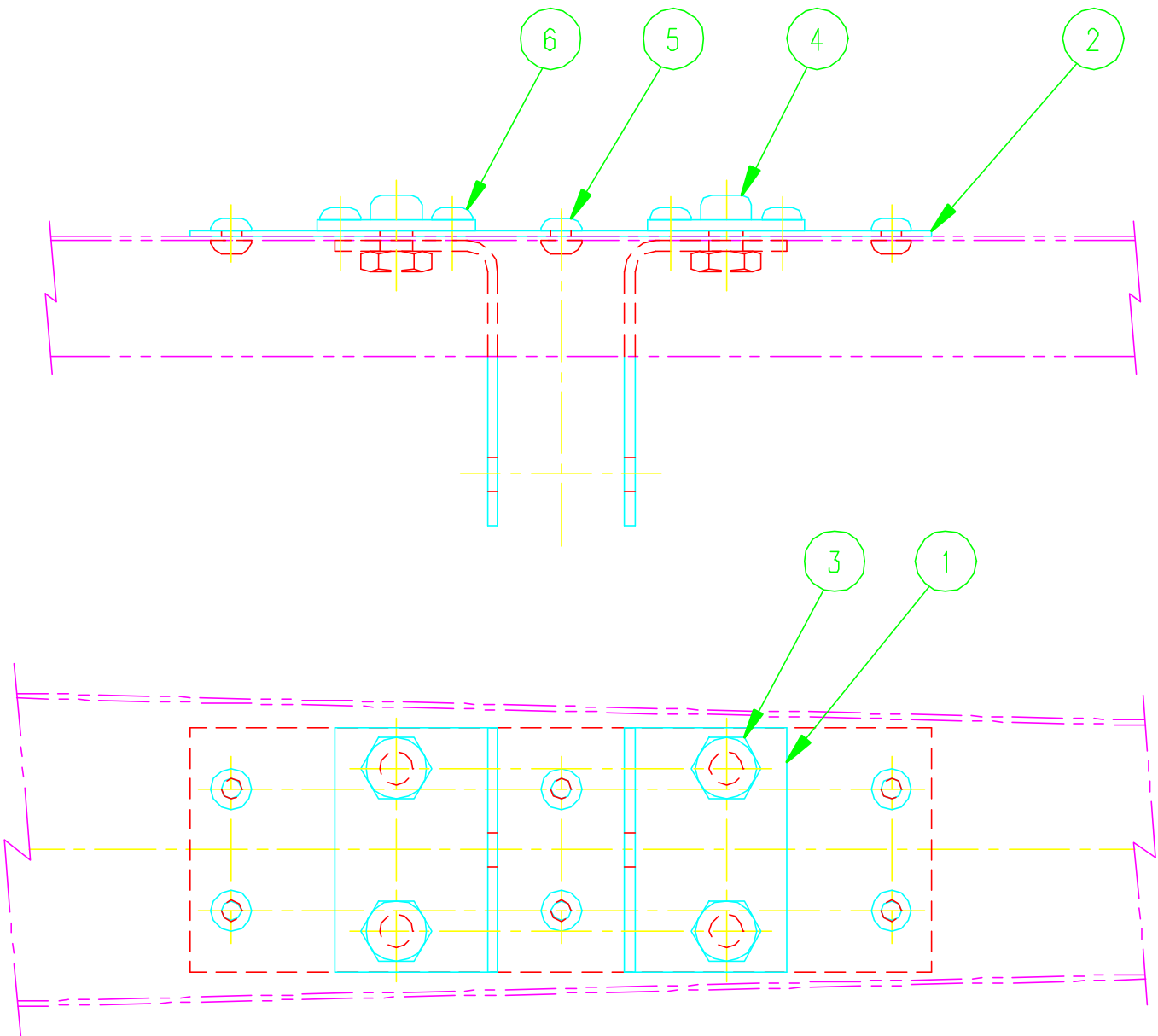

ITEM	PART No.	DESCRIPTION	No.	MAT'L
1	250-308	OUTBOARD STABILIZER HINGE .063 THK.	6	4130 STL.
2	250-386	HINGE BRACKET DOUBLER .032 THK.	5	2024 T3 AL.
3		AN3-3A BOLT	12	
4		AN366-F1032 NUT PLATE, SELF LOCK	12	
5		AN470-4-4 UNIVERSAL HEAD RIVET	18	
6		AN426-4-6 C'SUNK RIVET	24	

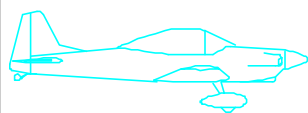

Mustang II
Mustang Aeronautics

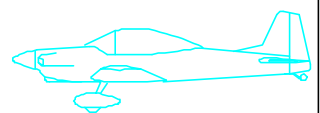

Title: REVISED HINGE BRACKET AND DOUBLER

Scale: 1:1

Approved By:

Drawn By: TRM

Date: 05/22/00

Mat'l:

Revised:

Drawing Number.:

XXX.XXX

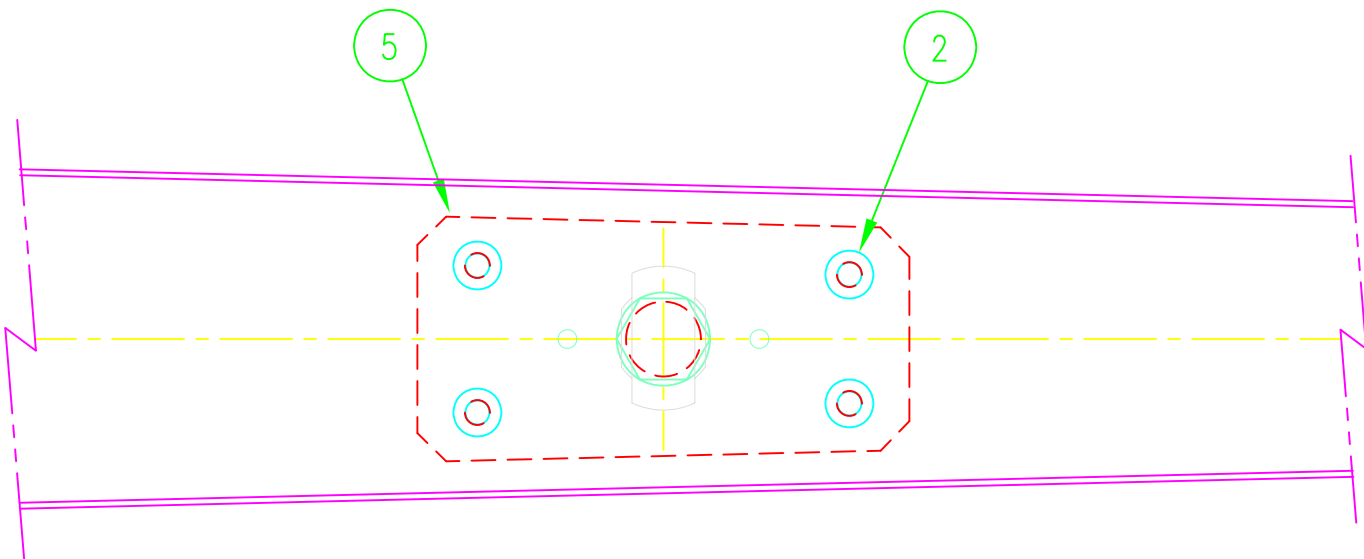
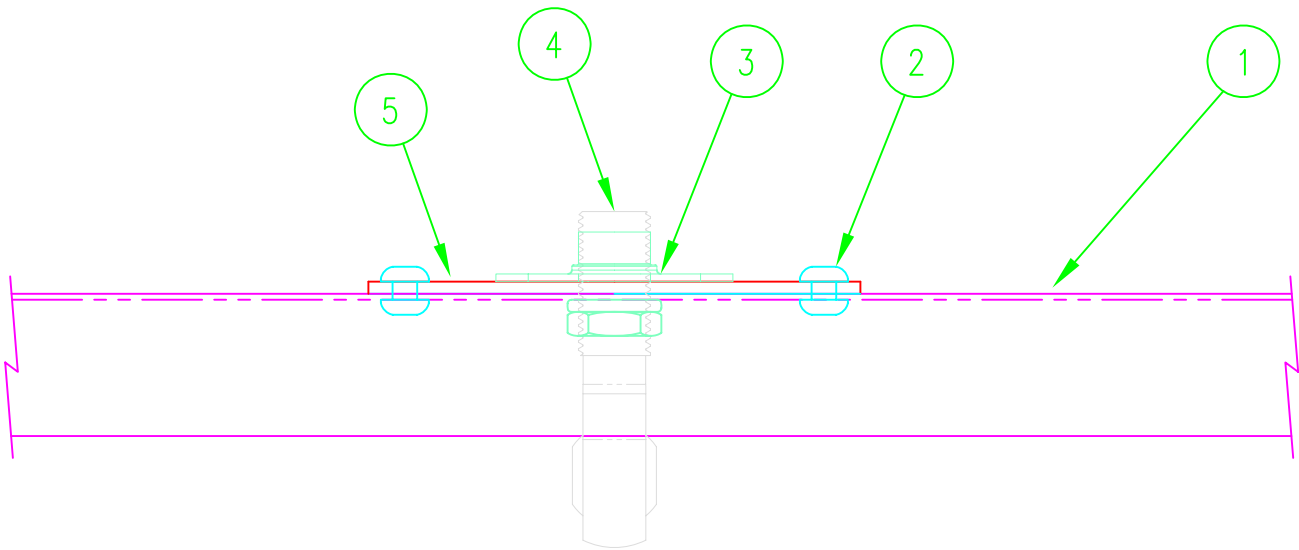

ITEM	PART No.	DESCRIPTION	Qty.	MAT'L
1	250.315	Elevator Spar	2	0.032 2024 AL
2		AN470AD4-5 Universal Head Rivet		
3		MS21047-L6 3/8" nutplate	3	
4		GMM-3M-670 RodEnd Bearing (MD36-14)	3	
5	250.329	Outboard Elev/Rudder Hinge Brkt Dblr	3	0.063 2024 AL

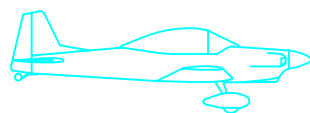

Mustang II
Mustang Aeronautics

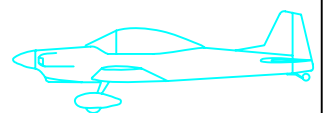

Title: Revised Outboard Elevator Hinge

Scale: 1:1 Approved By: Drawn By: CKT Date: 08/20/11

Mat'l: ASSEMBLY Revised: Drawing Number.: